

Hydro separator



548 series



01076/18 NA

Replaces 01076/16 NA

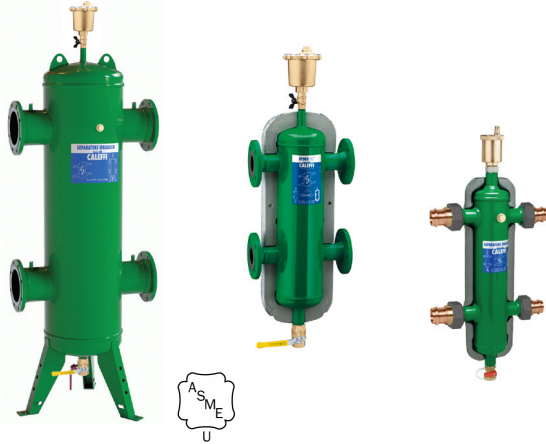

Function

The Caleffi 548 and NA548 series hydraulic separator creates a zone with a low pressure loss, which enables connected primary and secondary circuits to be hydraulically independent of each other; **the flow in one circuit does not create or interrupt flow in another.** Hydraulically decoupling primary and secondary circuits eliminates pump conflict.

This device includes an automatic high-capacity air vent with service valve to discharge accumulated air within the circuits.

Product range

548 series	Hydraulic separator in steel with union connections, drain and insulation.....connections 1" to 2" sweat union 1" to 2" NPT female union 1" to 2" press union
548 series	Hydraulic separator in steel with flanged connections, drain and insulation.....connections 2" to 4" ANSI
NA548 series	Hydraulic separator in steel with flanged connections, drain and insulation ASME and CRN.....connections 2" to 4" ANSI
NA548 series	Hydraulic separator in steel with flanged connections and drain, ASME and CRN.....connections 5" to 14" ANSI

Technical specifications

Threaded, sweat and press union connections

- Materials**
- body: epoxy resin painted steel
 - internal baffle: 300 series stainless steel
 - air vent body: brass
 - shut off and drain valve body: brass
 - union nuts: cast iron

Performance

- Suitable fluids: water and non-hazardous glycol solution up to 50%
 Max. operating pressure: 150 psi (10 bar)
 Working temperature range with insulation: 32–210°F (0–100°C)
 Working temperature range without insulation: 32–250°F (0–120°C)

- Connections** - main: 1", 1-1/4", 1-1/2", 2" NPT female with unions
 1", 1-1/4", 1-1/2", 2" sweat with unions
 1", 1-1/4", 1-1/2", 2" press with unions
 - thermo well tap: 1/2" straight thread female
 - lay length (press connections) size 1 inch : 9"
 size 1-1/4 inch: 9-3/4"
 size 1-1/2 inch: 11-1/4"
 size 2 inch: 12-3/4"
 - drain valve: 3/4" garden hose thread

Technical specifications of insulation

- Materials: double density closed cell expanded PEX
 Thickness: 3/4" (20 mm)
 Density: - internal part: 2 lb/ft³(30 kg/m³)
 - external part: 3.1 lb/ft³(50 kg/m³)
 Thermal conductivity: 32°F (0°C): 9 BTU-in/hr-ft²·°F (0.038 W/(m·K))
 -40°F (-40°C): 11 BTU-in/hr-ft²·°F (0.045 W/(m·K))
 Coefficient of resistance to the diffusion of vapor: >1,300
 Temperature range: 32–210°F (0–100°C)
 Reaction to fire (DIN4102): class B 2

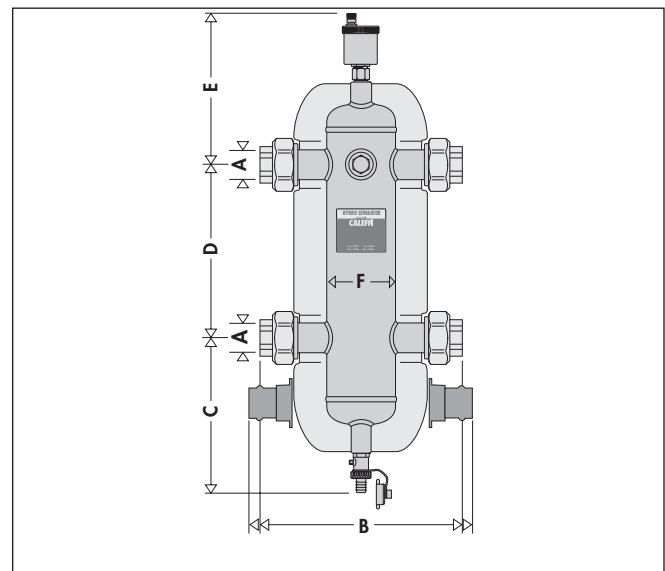

Code*	A	B swt/press	B npt	C	D	E	F	Wt. (lbs.)	Wt. (kg)
548006A/96A	1"	8 3/4"	8 1/2"	7"	8 5/8"	8 1/2"	3"	13	6.0
548007A/97A	1 1/4"	9 1/2"	9"	8 1/2"	9 1/2"	8 1/2"	3 1/2"	17	7.7
548008A/98A	1 1/2"	11"	10 1/2"	8 1/2"	10 1/4"	9 1/4"	4 1/2"	25	11.3
548009A/99A	2"	12 3/4"	11 1/2"	9 1/2"	11 1/8"	9 1/4"	5 3/4"	27	12.2
548066A	1"	10 1/4"	--	7"	8 3/8"	8 1/2"	3"	13	6.0
548067A	1 1/4"	11 3/4"	--	8 1/2"	9 1/2"	8 1/2"	3 1/2"	17	7.7
548068A	1 1/2"	14"	--	8 1/2"	10 1/4"	9 1/4"	4 1/2"	25	11.3
548069A	2"	15 3/4"	--	9 1/2"	11 1/8"	9 1/4"	5 3/4"	27	12.2

*54800: NPT female union connections; 54809: sweat union connections; 54806: press union connections.

Technical specifications

Flanged connections

Materials	- separator body:	epoxy resin painted steel
	- air vent body:	brass
	- shut off and drain valve body:	brass
	- internal baffle:	304 stainless steel

Performance

Suitable fluids:	water and non-hazardous glycol solution up to 50%
Max. operating pressure:	150 psi (10 bar)
Working temperature range with insulation:	32–220°F (0–105°C)
Working temperature range without insulation (vessel):	32–270°F (0–132°C)

Connections	- main:	2"-14" ANSI B16.5 150 CLASS RF
	- drain valve:	2 — 6": 1¼" NPT female 8 — 14": 2" NPT female
	- thermo well tap (8 — 14" only):	
	- front center:	¾" NPT female
	- inlet/outlet flanges:	½" NPT female

Agency approval

Series NA548 is designed and built in accordance with Section VIII, Division 1 of the ASME Boiler and Pressure Vessel Code and tagged and registered with the National Board of Boiler and Pressure Vessel Inspector, and CRN registered, and stamped for 150 psi (10 bar) working pressure, with ASME U stamp. 12" and 14" is CRN pending, contact Caleffi.

Technical specifications of insulation, flanged versions to 4"

Internal part

Materials:	rigid closed cell expanded polyurethane foam
Thickness:	2 3/8" (60 mm)
Density:	2.8 lb/ft³ (45 kg/m³)
Thermal conductivity:	6 BTU·in/hr·ft²·°F (0.023 W/(m·K))
Temperature range:	32–220°F (0–105°C)

Outer part

Materials:	embossed aluminum
Thickness:	7.0-mil (0.7 mm)
Reaction to fire (DIN 4102):	class 1

Head covers

Heat formed materials:	PS
------------------------	----

Dimensions

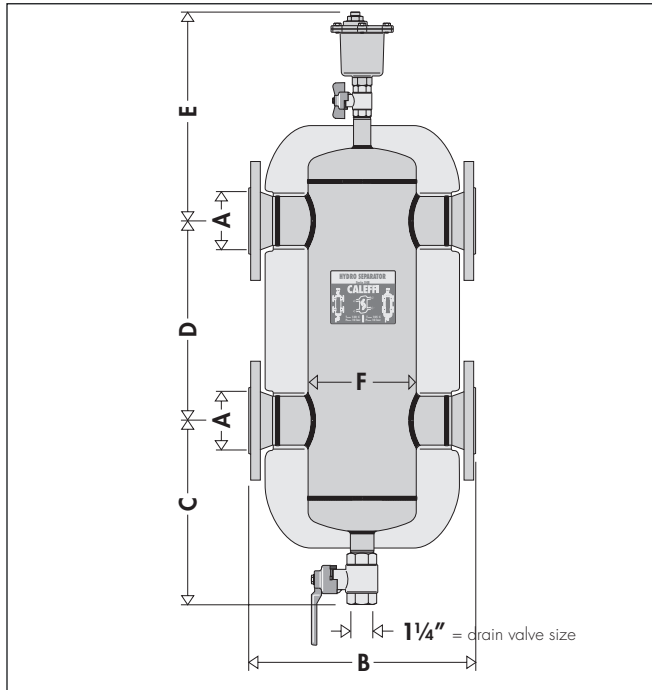

Code	A	B	C	D	E	F	Wt. (lbs.)	Wt. (kg)
*548052A	2"	13¾"	13"	13"	13½"	6"	75	34
*548062A	2½"	13¾"	13"	13"	13½"	6"	82	37
*548082A	3"	18¾"	15"	17¾"	15½"	8"	112	51
*548102A	4"	18½"	15"	17¾"	15½"	8"	117	53
NA548120A**	5"	25"	15"	22"	17½"	12¼"	220	100
NA548150A**	6"	25"	15"	22"	17½"	12¼"	231	105

*Add NA prefix to 2" to 4" flanged connection for ASME approved, CRN registered.

**Without insulation.

NA prefix indicates ASME tagged and registered with the National Board of Boiler and Pressure Vessel Inspectors and CRN registered, with ASME U stamp.

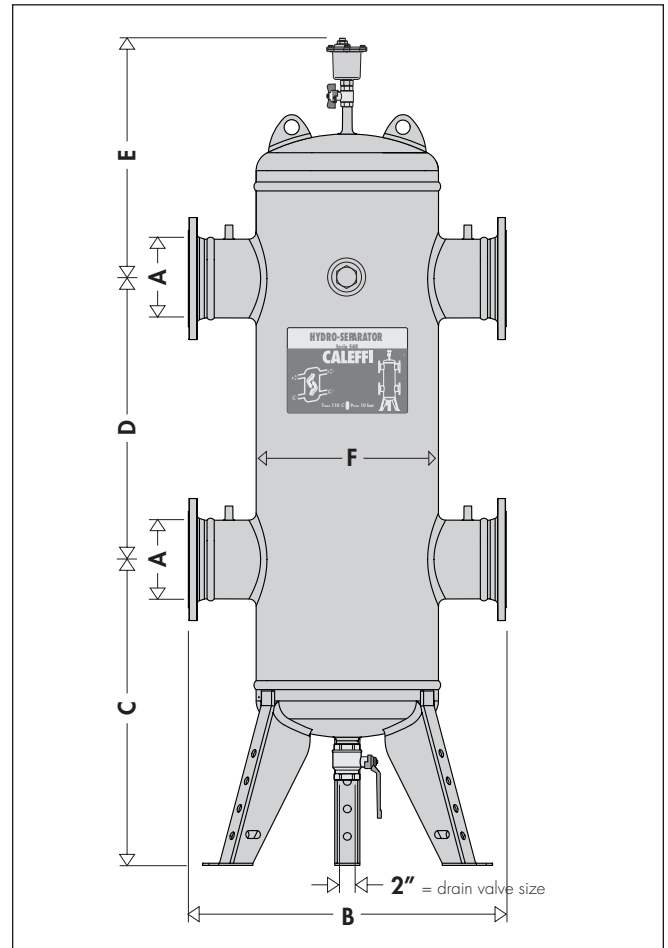

Code	A	B	C	D	E	F	Wt. (lbs.)	Wt. (kg)
NA548200A	8"	35½"	34"	39½"	25½"	20"	520	236
NA548250A	10"	41¾"	36⅞"	43⅞"	27⅞"	26"	725	330
NA548300A	12"	46½"	37⅞"	47¼"	29⅞"	30"	1,100	500
NA548350A	14"	52"	38⅞"	58⅞"	34½"	36"	1,400	635

NA prefix indicates ASME tagged and registered with the National Board of Boiler and Pressure Vessel Inspectors and CRN registered (except 14" CRN pending, contact Caleffi), with ASME U stamp. Insulation is not included.

Operating principle

When a single system contains a primary production circuit, with its own pump, and a secondary user circuit, with one or more distribution pumps, operating conditions may arise in the system whereby the pumps interact, creating abnormal variations in circuit flow rates and pressures.

The hydraulic separator creates a zone with a low pressure loss, which enables the primary and secondary circuits connected to it to be hydraulically independent of each other; **the flow in one circuit does not create a flow in the other if the pressure loss in the common section is negligible.**

In this case, the flow rate in the respective circuits depends exclusively on the flow rate characteristics of the pumps, preventing reciprocal influence caused by connection in series.

Therefore, using a device with these characteristics means that the flow in the secondary circuit only circulates when the relevant pump is on, permitting the system to meet the specific load requirements at that time.

When the secondary pump is off, there is no circulation in the secondary circuit; the whole flow rate produced by the primary pump is by-passed through the separator.

With the hydraulic separator, it is therefore possible to have a primary production circuit with a constant flow rate and a secondary distribution circuit with a variable flow rate; these operating conditions are typical of modern heating and cooling systems.

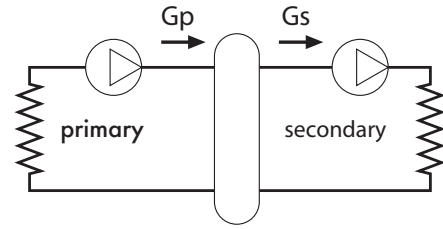

Three possible hydraulic balance situations are shown below.

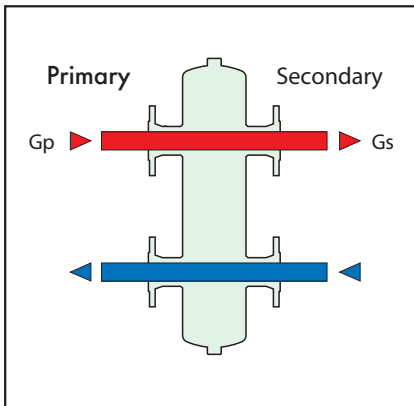

$$G_{\text{primary}} = G_{\text{secondary}}$$

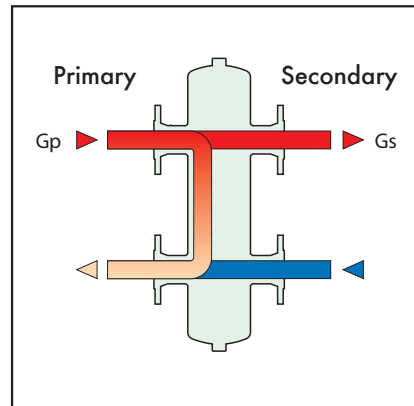

$$G_{\text{primary}} > G_{\text{secondary}}$$

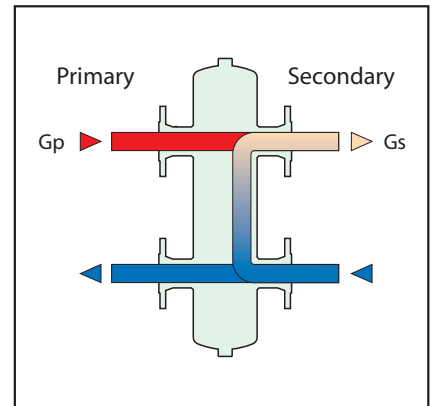

$$G_{\text{primary}} < G_{\text{secondary}}$$

Construction details

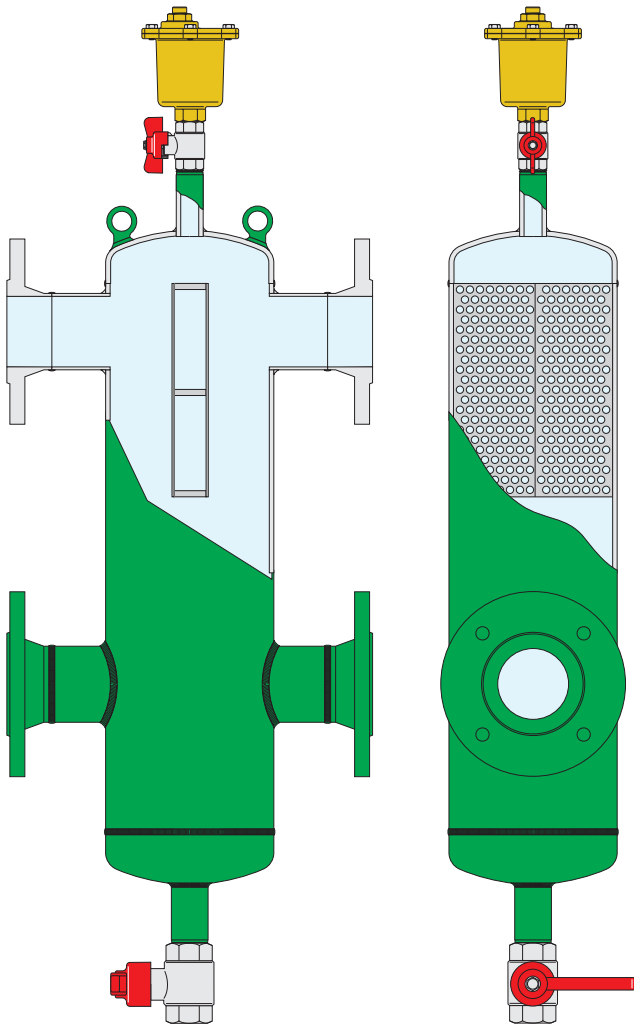

Isolating the air vent valve

In flanged separators, the air vent is isolated manually, using a shut-off ball valve. In union separators, however, the air vent body is automatically isolated by the check valve, which closes when the air vent body is removed.

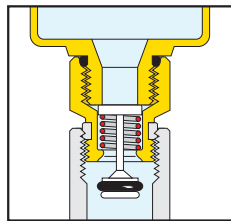

Insulation

Hydraulic separators are available complete with a hot preformed insulation shell. In the flanged series, up to 4", the insulation is made of a shell in expanded polyurethane foam covered with an aluminium layer. In the union sweat or thread version the insulation is made of a pre-formed shell in double density closed cell expanded PEX. This insulation ensures not only perfect heat insulation but also the tightness required to prevent atmospheric water vapors from entering the unit. For these reasons, this type of insulation can also be used in cooling water circuits, as it prevents the formation of condensate on the surface of the separator body.

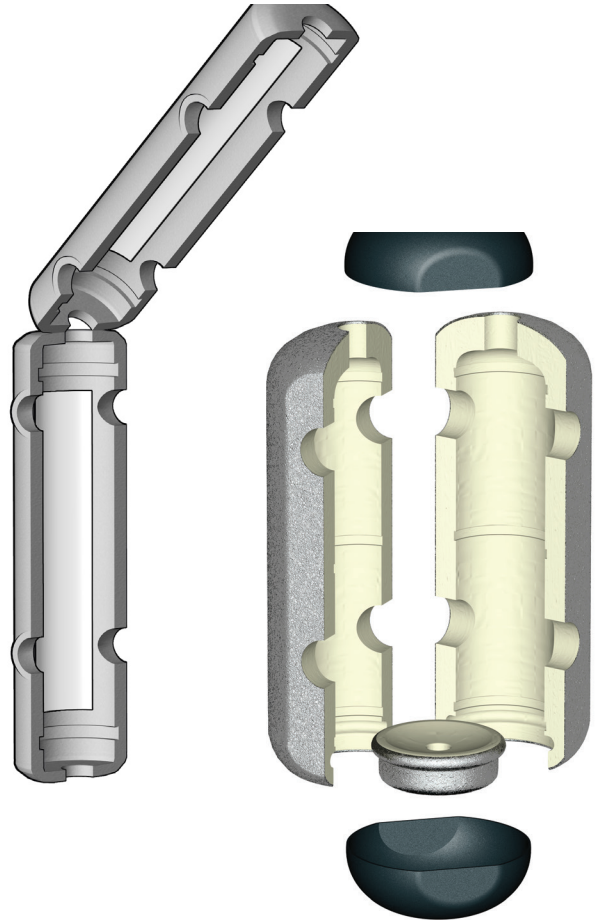

Hydraulic characteristics

The hydraulic separator should be sized according to the maximum flow rate value at the inlet. The selected design value must be the greatest required flow rate of either the primary circuit or the secondary circuit.

Union connections

Size	1"	1 1/4"	1 1/2"	2"
gpm	11	18	26	37
l/s	0.7	1.1	1.6	2.3
gallons	0.5	0.7	1.3	3.5
liters	1.9	2.6	4.9	13.2

Flanged connections

Size	2"	2 1/2"	3"	4"	5"	6"	8"	10"	12"	14"
gpm	60	80	124	247	300	484	792	1330	1850	2500
l/s	3.8	5.0	7.8	16	19	30	50	84	117	158
gallons	4.0	4.0	8.0	8.0	22.5	23	95	175	255	450
liters	15.1	15.1	30.3	30.3	85.2	87.0	360	662	965	1703

Application diagram

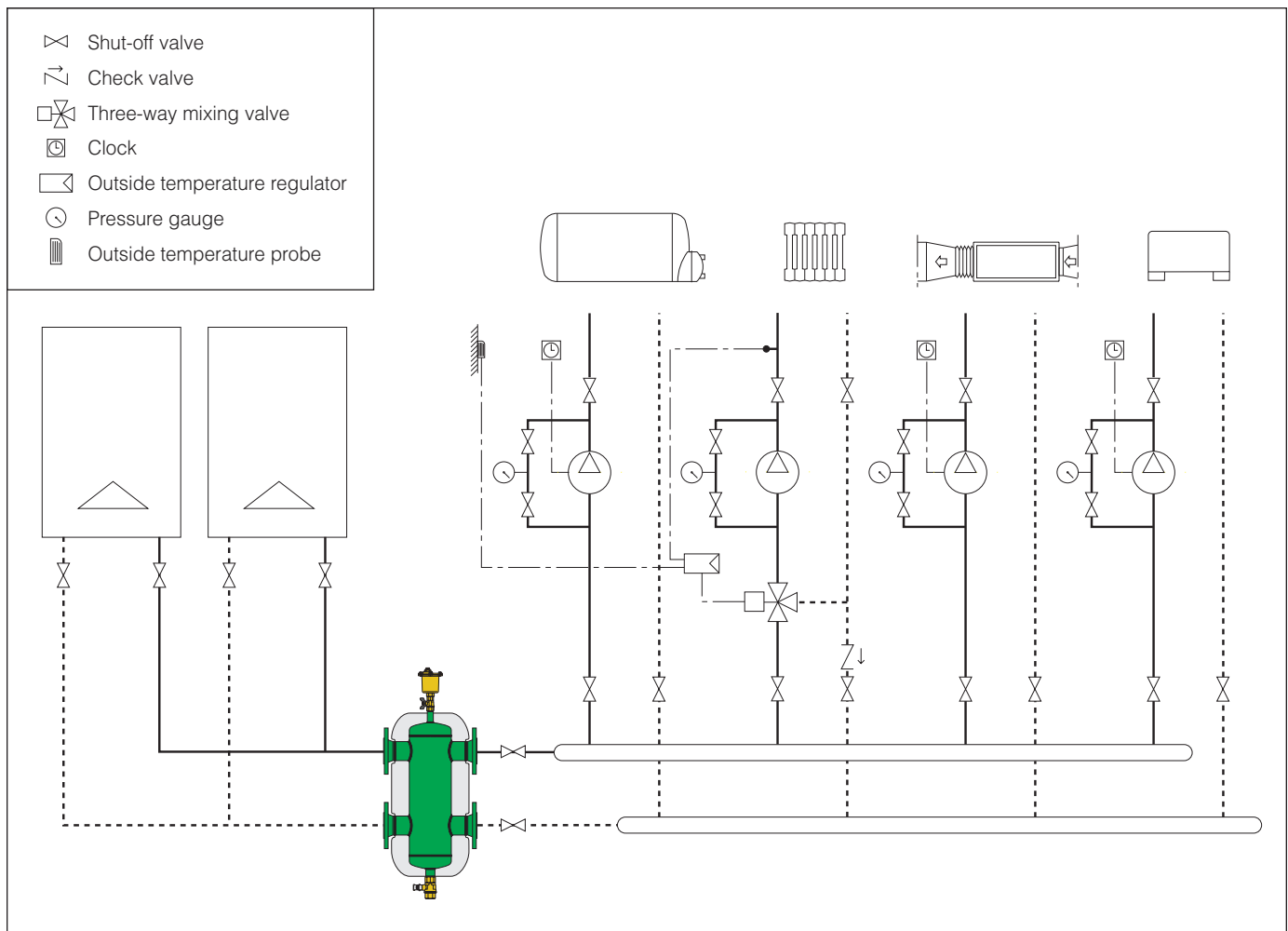

SPECIFICATION SUMMARIES

Hydro Separator 548 series

Hydraulic separator. NPT female, sweat and press union connections 1", 1-1/4", 1-1/2" and 2". Epoxy resin painted steel body. Cast iron union nuts. 300 series stainless steel internal baffle. Working temperature range of 32–210°F (0–100°C) with insulation, 32–250°F (0–120°C) without insulation. Glycol maximum 50%. Max. working pressure 150 psi (10 bar). Supplied with: automatic air vent with automatic service check valve 1/2" NPT female outlet connection and brass body. Drain ball valve brass body with hose connection. Pre-formed double density closed cell expanded PE-X foam shell insulation with external embossed aluminium cover. 1/2 inch female straight thread thermometer pocket well front center. Provide temperature pocket well kit, code NA10425.

Hydro Separator 548 series

Hydraulic separator. ANSI B16.5 CLASS 150 RF flanged connections 2", 2-1/2", 3", and 4". Epoxy resin painted steel body. 304 stainless steel internal baffle. Vessel working temperature range of 32–220°F (0–105°C) with insulation, 32–270°F (0–132°C) without insulation. Glycol maximum 50%. Max. working pressure 150 psi (10 bar). Supplied with: automatic air vent with 3/4" NPT female outlet connection and brass body. Brass body 3/4" NPT female shut-off ball valve with T-handle for air vent. Drain ball valve brass body with 1-1/4" NPT female connection. Rigid closed cell expanded polyurethane foam shell insulation with external embossed aluminium cover.

Hydro Separator NA548 series

Hydraulic separator. ANSI B16.5 CLASS 150 RF flanged connections 2", 2-1/2", 3", 4", 6", 8", 10", 12" and 14". Epoxy resin painted steel body. 304 stainless steel internal baffle. Vessel working temperature range of 32–220°F (0–105°C) with insulation, 32–270°F (0–132°C) without insulation. Glycol maximum 50%. Max. working pressure 150 psi (10 bar). Supplied with: automatic air vent with 3/4" NPT female outlet connection and brass body. Brass body 3/4" NPT female shut-off ball valve for air vent. Drain ball valve brass body with 1-1/4" NPT female connection for separator sizes 2–6"; 2" NPT female connections for separator size 8–14". For separator size 8–14" only thermometer pocket well on front center 3/4" NPT female; and on inlet/outlet flanges 1/2" NPT female. Rigid closed cell expanded polyurethane foam shell insulation with external embossed aluminium cover for 2, 2-1/2, 3 and 4 inch sizes. The separator is designed and built in accordance Section VIII, Division 1 of the ASME Boiler and Pressure Vessel Code and tagged and registered with the National Board of Boiler and Pressure Vessel Inspector, and CRN registered (size 12" and 14" pending, contact Caleffi), and stamped for 150 psi (10 bar) working pressure, with ASME U stamp.

We reserve the right to change our products and their relevant technical data, contained in this publication, at any time and without prior notice.



Caleffi North America, Inc.
3883 W. Milwaukee Road
Milwaukee, WI 53208
Tel: 414-238-2360 · Fax: 414-238-2366
sales@caleffi.com · www.caleffi.com
© Copyright 2018 Caleffi North America, Inc.