

DIRTCAL® - DIRTMAG® dirt separator



5462-5463-5465 series



01137/16 NA
Replaces 01137/15 NA

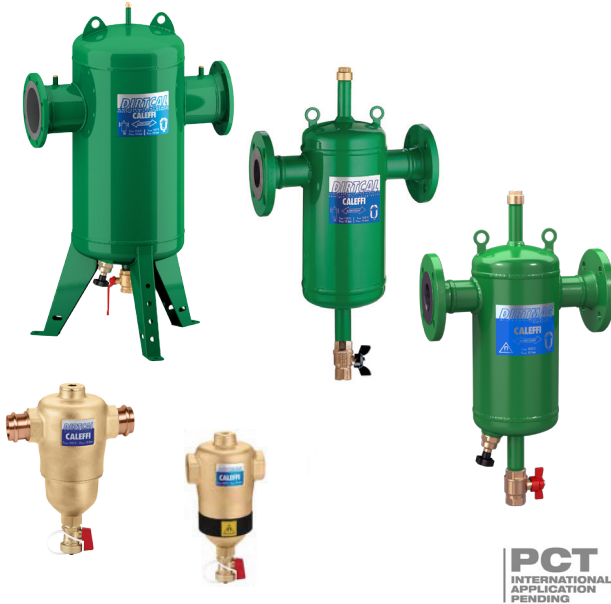

PCT
INTERNATIONAL
APPLICATION
PENDING

Product range

5462 series	DIRTCAL® dirt separator, in brass	connections ¾" to 2" NPT female; 1" to 2" integral sweat; 1" and 1-¼" integral press
5463 series	DIRTMAG® magnetic dirt separator, in brass	connections 1" to 2" NPT female and integral sweat; 1" and 1-¼" integral press
5465 series	DIRTCAL® dirt separator, in steel.....	connections 2" to 4" ANSI flanged
5465M series	DIRTMAG® magnetic dirt separator, in steel.....	connections 2" to 4" ANSI flanged
NA5465 series	DIRTCAL® dirt separator, in steel, ASME & CRN	connections 2" to 6" ANSI flanged
NA5465M series	DIRTMAG® magnetic dirt separator, in steel, ASME.....	connections 2" to 8" ANSI flanged

Technical specifications

Brass body dirt separators and magnetic dirt separators

Materials	- body, dirt collection chamber and top plug:	brass
	- internal element:	glass reinforced nylon PA66G30
	- hydraulic seal:	EPDM
	- drain valve:	brass
	- magnet (5463 series):	neodymium rare-earth

Performance

Suitable fluids:	water, glycol solution
Max. percentage of glycol:	50%
Max. working pressure:	150 psi (10 bar)
Temperature range:	32-250°F (0-120°C)
Particle separation capacity:	to 5 µm (0.2 mil)
Ferrous impurities separation efficiency (magnetic models):	up to 100% removal

Connections	- main:	¾", 1", 1-¼", 1-½" and 2" NPT female 1", 1-¼", 1-½" and 2" integral sweat 1" and 1-¼" integral press
	- lay length (press connections):	size 1 inch: 4-¾" size 1-¼ inch: 5-1/8"
	- top:	½" NPT female (with plug)
	- drain:	¾" garden hose connection

Steel body dirt separators and magnetic dirt separators

Materials	- body:	epoxy resin painted steel
	- top cap:	brass
	- hydraulic seal:	non-asbestos fiber
	- drain valve:	brass

Function

In heating and air conditioning control systems, the circulation of water containing impurities may result in rapid wear and damage to components such as pumps and control valves. It also causes blockages in heat exchangers, heating elements and pipes, resulting in lower thermal efficiency within the system.

The dirt separator removes these dirt particles, collecting them in a large collection chamber from which they can be flushed even while the system is in operation. This device is capable of efficiently removing even the smallest particles, with very low head loss.

The DIRTMAG® magnetic dirt separator removes both ferrous and non-ferrous impurities continuously, featuring powerful removable magnets that remove up to 100% of the ferrous impurities, including magnetite, that can form in a hydronic system. The DIRTMAG® has 2 ½ times the removal performance of a standard dirt separator.

Insulation shells are available separately for brass models.

- internal element:	5465, NA5465	stainless steel
	5465M, NA5465M	stainless steel and HDPE
- magnet(M series):		neodymium rare - earth
- magnet probe drywell:		brass

Performance

Suitable fluids:	water, glycol solution
Max. percentage of glycol:	50%
Max. working pressure:	150 psi (10 bar)
Temperature range (vessel):	32-270°F (0-132°C)
Particle separation capacity:	to 5 µm (0.2 mil)
Ferrous impurities separation efficiency (magnetic models):	up to 100% removal

Connections	- flanged:	(NA5465) 2"-6" ANSI B16.5 150 CLASS RF (M series) 2"-8" ANSI B16.5 150 CLASS RF
	- top:	¾" NPT male (with cap)
	- thermo well tap (8" only):	
	-inlet/outlet flanges:	½" NPT female
	- drain valve:	sizes 2 - 6 inch: 1" NPT size 8 inch: 2" NPT

Agency approval

- series NA5465 and NA5465M designed and built in accordance with Section VIII, Div. 1 of the ASME Boiler and Pressure Vessel Code and tagged and registered with the National Board of Boiler and Pressure Vessel Inspectors, stamped for 150 psi (10 bar) working pressure with ASME U-Stamp.
- series NA5465 is CRN Registered, series NA5465M CRN pending, contact Caleffi.

Dimensions

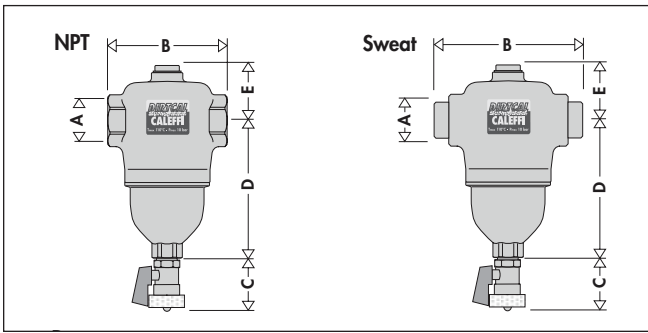

Code	A	B	C	D	E	Wt. lb (kg)
546205A	¾" NPT	4 ⁵ / ₁₆ "	1¼"	5"	2"	4.2 (1.9)
546206A	1" NPT	4 ⁵ / ₁₆ "	1¼"	5"	2"	4.2 (1.9)
546207A	1¼" NPT	4 ⁷ / ₈ "	1¼"	6"	2"	5.3 (2.4)
546208A	1½" NPT	4 ⁷ / ₈ "	1¼"	6"	2"	6.2 (2.8)
546209A	2" NPT	5 ¹ / ₈ "	1¼"	6"	2"	6.2 (2.8)
546228A	1" SWT	5 ¹ / ₁₆ "	1¼"	5"	2"	4.2 (1.9)
546235A	1¼" SWT	5 ³ / ₁₆ "	1¼"	6"	2"	4.2 (1.9)
546241A	1½" SWT	5¾"	1¼"	6"	2"	4.9 (2.2)

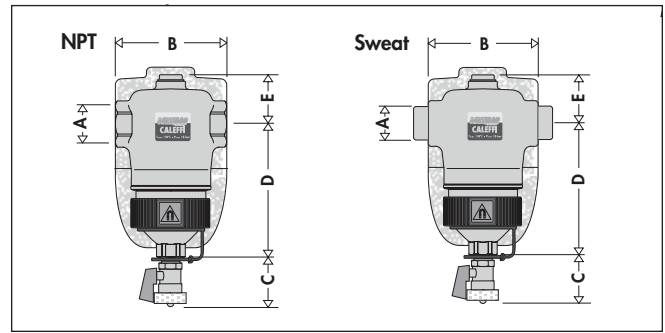

Code	A	B	C	D	E	Wt. lb (kg)
546306A	1" NPT	4 ⁵ / ₁₆ "	1¼"	5"	2"	4.2 (1.9)
546328A	1" SWT	5 ¹ / ₁₆ "	1¼"	5"	2"	4.2 (1.9)
546307A	1¼" NPT	4 ⁷ / ₈ "	1¼"	6"	2"	5.3 (2.8)
546335A	1¼" SWT	5 ³ / ₁₆ "	1¼"	6"	2"	4.2 (1.9)
546308A	1½" NPT	4 ⁷ / ₈ "	1¼"	6"	2"	6.2 (2.8)
546341A	1½" SWT	5¾"	1¼"	6"	2"	4.9 (2.2)
546309A	2" NPT	5 ¹ / ₈ "	1¼"	6"	2"	6.2 (2.8)

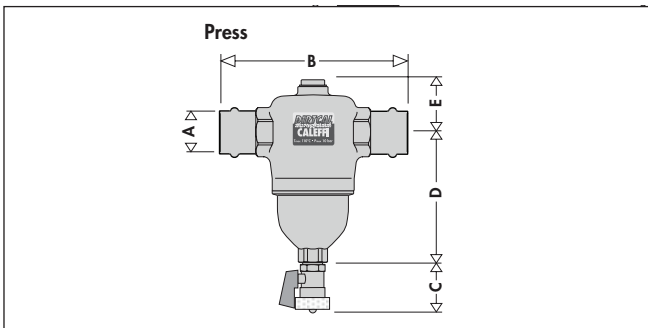

Code	A	B	C	D	E	Wt lb (kg)
546266A	1" press	6 ³ / ₁₆ "	1¼"	5"	2"	4.5 (2.0)
546267A	1¼" press	7 ⁷ / ₁₆ "	1¼"	6"	2"	5.6 (2.5)

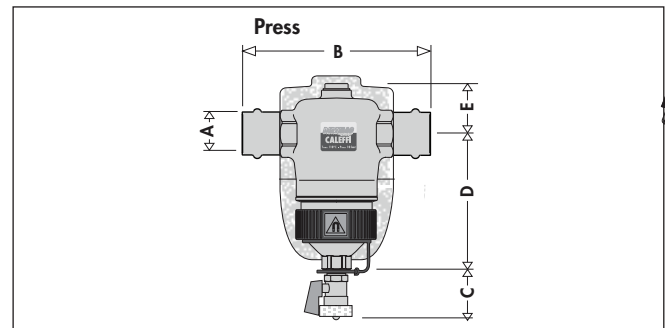

Code	A	B	C	D	E	Wt lb (kg)
546366A	1" press	6 ³ / ₁₆ "	1¼"	5"	2"	4.5 (2.0)
546367A	1¼" press	7 ⁷ / ₁₆ "	1¼"	6"	2"	5.6 (2.5)

NOTE: Drawings may not reflect the actual size of the separators.

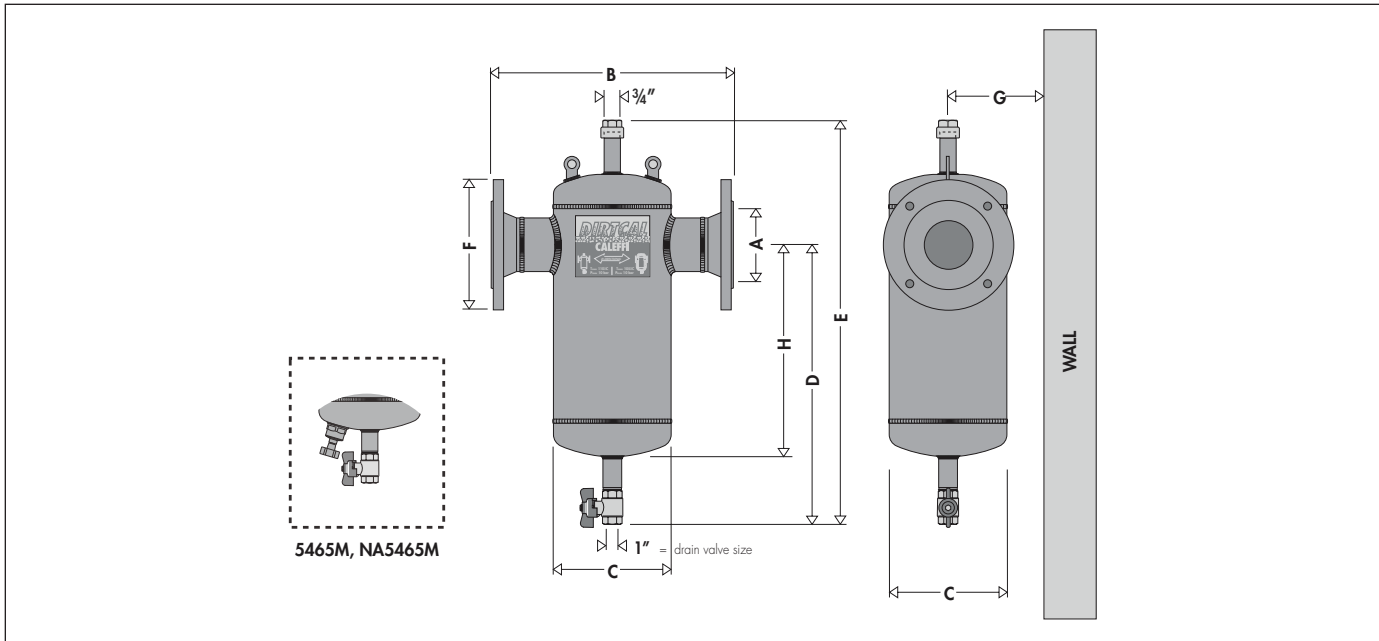

Code	A	B	C	D	E	F	G*	H	Capacity (gal)	Wt. lb (kg)	M Wt. lb (kg)
546550A; M	2"	13 ³ / ₄ "	6 ⁵ / ₈ "	16 ⁵ / ₁₆ "	23 ⁷ / ₈ "	6"	6 ⁵ / ₁₆ "	12"	1.8	38 (17.0)	41 (20)
546560A; M	2 ¹ / ₂ "	13 ³ / ₄ "	6 ⁵ / ₈ "	16 ⁵ / ₁₆ "	23 ⁷ / ₈ "	7"	6 ⁵ / ₁₆ "	12"	1.8	38 (17.0)	41 (20)
546580A; M	3"	18 ³ / ₈ "	8 ⁵ / ₈ "	20 ¹¹ / ₁₆ "	30 ⁵ / ₈ "	7 ¹ / ₂ "	7 ⁵ / ₁₆ "	13 ³ / ₈ "	4.8	55 (25.0)	58 (26)
546510A; M	4"	18 ³ / ₈ "	8 ⁵ / ₈ "	20 ¹¹ / ₁₆ "	30 ⁵ / ₈ "	9"	7 ⁵ / ₁₆ "	13 ³ / ₈ "	4.8	55 (25.0)	58 (26)
NA546550A; M	2"	13 ³ / ₄ "	6 ⁵ / ₈ "	16 ⁵ / ₁₆ "	23 ⁷ / ₈ "	6"	6 ⁵ / ₁₆ "	12"	1.8	38 (17.0)	41 (20)
NA546560A; M	2 ¹ / ₂ "	13 ³ / ₄ "	6 ⁵ / ₈ "	16 ⁵ / ₁₆ "	23 ⁷ / ₈ "	7"	6 ⁵ / ₁₆ "	12"	1.8	38 (17.0)	41 (20)
NA546580A; M	3"	18 ³ / ₈ "	8 ⁵ / ₈ "	20 ¹¹ / ₁₆ "	30 ⁵ / ₈ "	7 ¹ / ₂ "	7 ⁵ / ₁₆ "	13 ³ / ₈ "	4.8	55 (25.0)	58 (26)
NA546510A; M	4"	18 ³ / ₈ "	8 ⁵ / ₈ "	20 ¹¹ / ₁₆ "	30 ⁵ / ₈ "	9"	7 ⁵ / ₁₆ "	13 ³ / ₈ "	4.8	55 (25.0)	58 (26)
NA546512A; M	5"	25"	12 ³ / ₄ "	23 ³ / ₁₆ "	34 ¹⁵ / ₁₆ "	10"	9 ³ / ₈ "	17 ³ / ₁₆ "	13.7	138 (63.0)	141 (65)
NA546515A; M	6"	25"	12 ³ / ₄ "	23 ³ / ₁₆ "	34 ¹⁵ / ₁₆ "	11"	9 ³ / ₈ "	17 ³ / ₁₆ "	13.7	148 (67.0)	151 (70)
NA546520AM	8"	35 ¹ / ₂ "	20"	34 ¹ / ₂ "	53"	13 ¹ / ₂ "	13"	28 ³ / ₄ "	55.7	NA	335(152)

*This dimension allows for a minimum of 3" wall clearance to accommodate insulation if used.

M indicates models with magnetic probe.

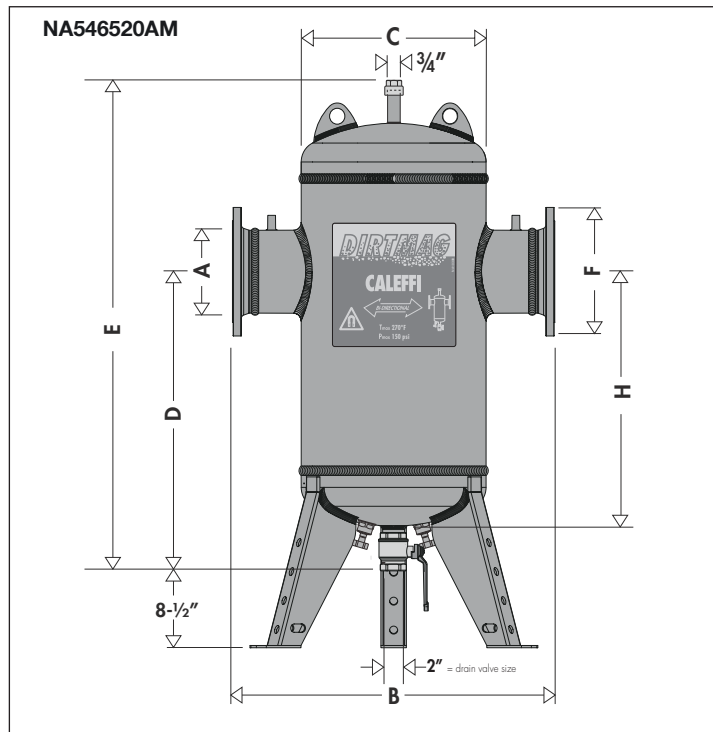

Operating principle DIRTCAL®

The dirt separating action performed by the internal element (1) offers little resistance to the flowing medium while ensuring dirt separation. The particles collide with the concentric diamond pattern mesh surfaces and then settle to the bottom in the dirt collection chamber (2), and not by filtration unlike mesh strainers; which, over time, get progressively clogged. By contrast, the DIRTCAL®'s low-velocity zone dirt separator function efficiently removes the particles to as small as 5µm (0.2 mil) with very low head loss. The dirt can then be removed through the bottom drain port (3).

The collected dirt can then be discharged, even with the system running, by opening the drain valve (3) with the handle (4).

Construction details

Low head losses and performance maintained over time

The dirt separating action performed by the dirt separator is based on using the internal element (1) with concentric diamond pattern mesh surfaces instead of an ordinary filter. The element offers little resistance to the medium flow while ensuring dirt separation. This occurs due to the particles colliding with the concentric diamond pattern mesh surfaces and then settling to the bottom, and not by filtration; which, over time, gets progressively clogged. By contrast, the DIRTCAL® low velocity- zone dirt separator efficiently removes the particles to as small as 5 µm (0.2 mil) with very low head loss. The dirt collection chamber (2) at the bottom of the DIRTCAL® is at the right distance from the inlet and outlet connections that the collected dirt particles are not affected by the swirling flow through the bottom drain port, even with the system running, by opening the drain valve (3) with the handle (4).

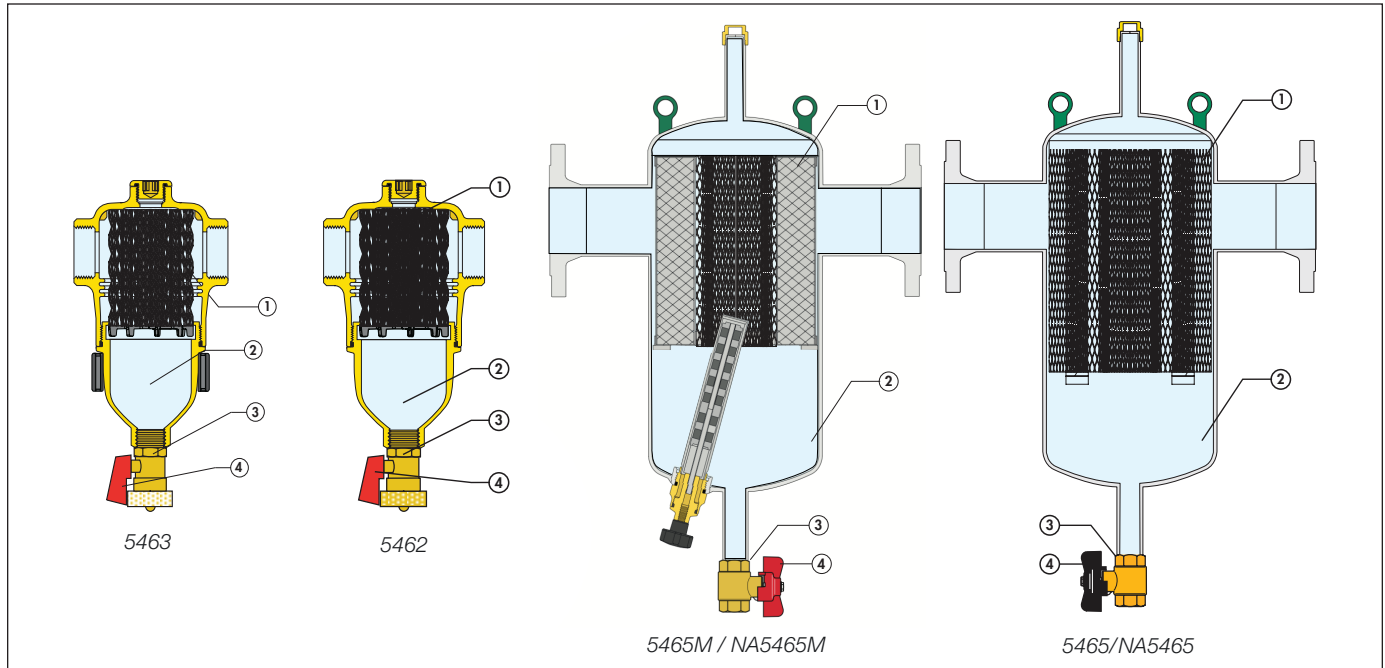

Geometric structure and large dirt collection chamber

The geometrical structure of DIRTCAL® reduces the flow media velocity to help separate dirt particles. The dirt collection chamber has the following features:

- It is located at the bottom of the device at such a distance from the connections that the collected dirt is not affected by the swirl of the flow through the mesh element.
- It has enough capacity to increase the amount of dirt stored and therefore decreases the frequency of emptying it compared to filters that need to be cleaned frequently.

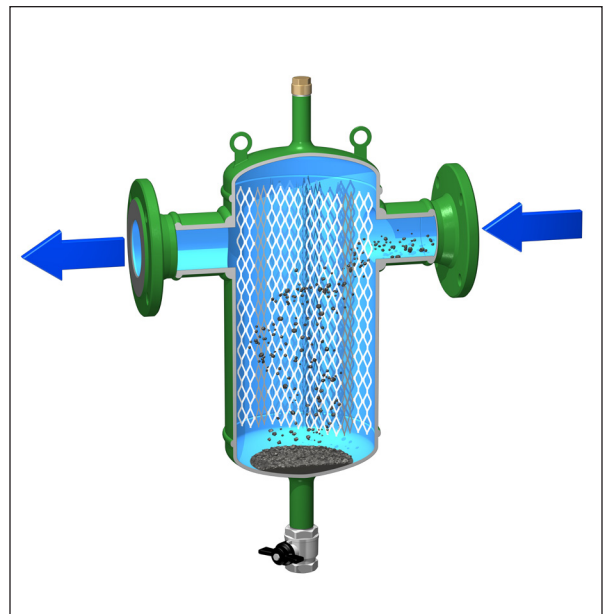

Operating principle DIRTMAG®

Non-ferrous and ferrous impurities, including magnetite, in hydronic systems can deposit onto heat exchanger surfaces and accumulate in pump cavities causing reduced thermal efficiency and premature wear. The small and often microscopic magnetic particles, called magnetite, form when iron or steel corrodes. Highly abrasive, the extremely fine particles are difficult to remove by traditional means. DIRTMAG® separators offer highly efficient separation of typical dirt as well as magnetite. The versatile DIRTMAG® magnetic dirt separator removes both ferrous and non-ferrous impurities continuously. In addition to removing sand and rust impurities with an internal element in a low-velocity-zone chamber, the DIRTMAG® features a powerful removable magnet below the flow line for fast and effective capture of ferrous impurities. The magnet removes up to 100% of the ferrous impurities, including magnetite, that can form in a hydronic system.

For the brass DIRTMAG®, the ferrous impurities are captured by a strong neodymium rare-earth magnetic field created by a powerful removable magnet around the body below the flow line.

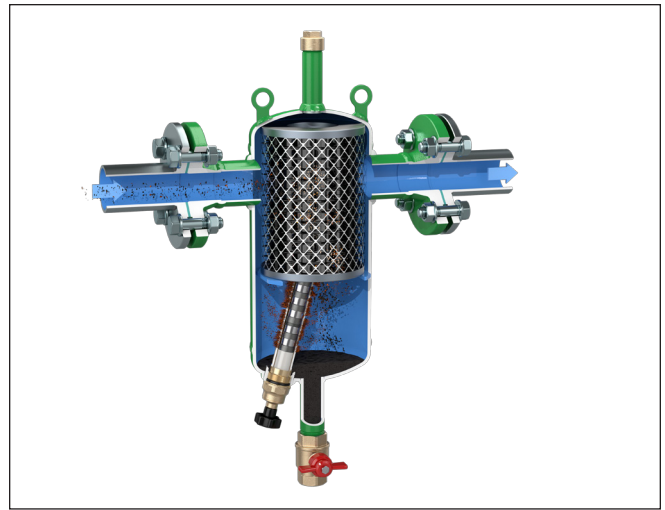
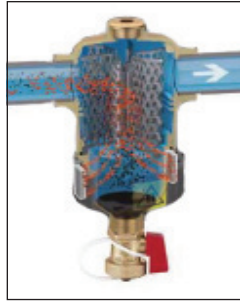

For the steel DIRTMAG®, the ferrous impurities are captured by a concentrated magnetic field created by a stack of neodymium rare-earth magnets positioned inside a brass dry-well below the flow stream.

Draining off dirt and ferrous impurities

The dirt separator collection chamber has a drain valve. Using the handle provided it is possible to drain off the accumulated dirt particles even with the system in operation.

For the brass DIRTMAG®, captured impurities are easily flushed by unclamping the magnetic collar and purging.

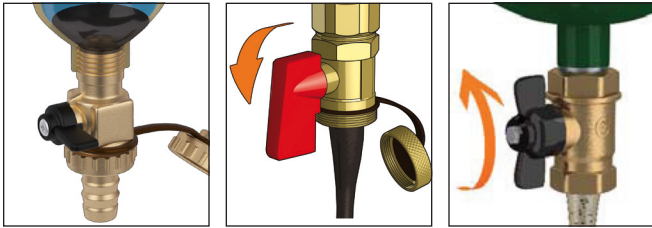

To purge the ferrous impurities in the steel DIRTMAG®, the flexible magnetic stack is removed from the brass dry-well and, with the system still running, the drain valve is opened. Aided by the system pressure, the dirt and ferrous impurities, including magnetite, flushes out quickly and effectively.

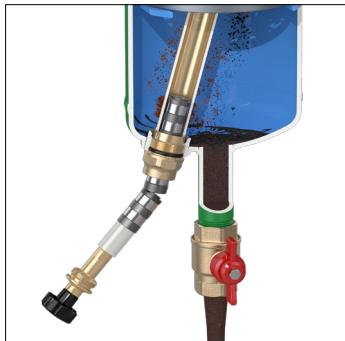

Maintenance

To perform maintenance, simply use a 26 mm hexagon wrench (1) to unscrew the dirt collection chamber, of the brass DIRTMAG® and DIRTMAG®, to which the inner mesh element is connected for removal and cleaning.

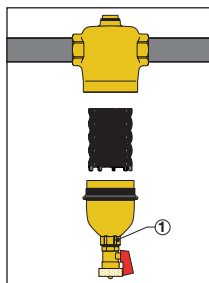

Use of top connector

The connector on top of the dirt separator can be used for optional installation of an automatic air vent valve, Caleffi code 502243A for the threaded or sweat versions, 5462 and 5463 Series (A), replacing the standard 1/2" NPT Male plug (code NA10044). Use Caleffi code 501502A for the flanged version 5465, NA5465, 5465M and NA5465M series (C) — replacing the standard 3/4" NPT End Cap (code 41525).

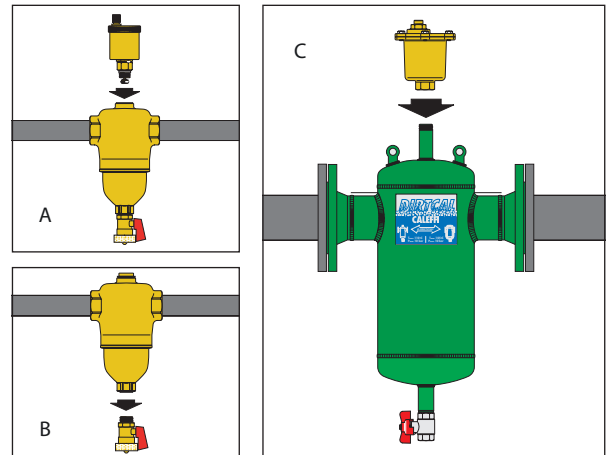

Use of bottom connector

The dirt separators come complete with drain valves installed on the bottom port: Caleffi code 538402 FD for horizontal threaded or sweat versions, 5462 series (B); and code NA39753 (1" NPT female) for in-line flanged versions, 5465, NA5465, 5465M and NA5465M series (C); and code NA59600 (2" NPT female) for free-standing flanged versions, 8" NA546520AM.

Particle separation capacity — dirt separator efficiency

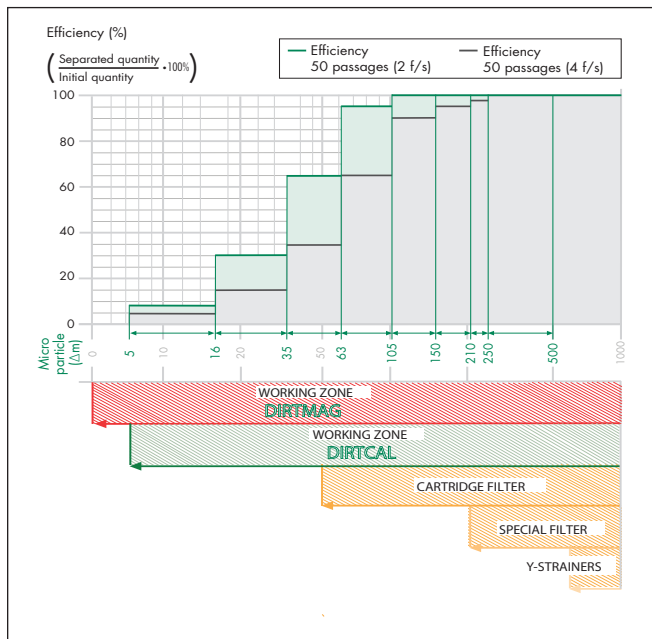

Comparison of head losses: dirt separator to Y-strainers

Y-strainers entrap dirt within a basket made of stainless steel or brass mesh, selected for the size of the largest particle. Particles smaller than the mesh size may pass through. On most Y-strainers, the basket must be removed periodically to clear the trapped debris. As the debris collects in the basket, flow is impeded resulting in increasing pressure drop and therefore higher head loss. The dirt separation function in the DIRTAL® and DIRTMAG® utilizes the low-velocity-zone principle. The flow velocity of fluid flowing into the dirt separation chamber is greatly reduced causing the entrained dirt particles to drop due to their density.

The internal element provides surfaces that assist in separating dirt particles and guide them downward to ultimately settle to the bottom of the separator. The dirt separator only creates about 25% of the pressure drop of a comparable sized, clean basket Y-strainer, depending on mesh size and amount of filtered debris. These head losses are not affected by the amount of dirt collected.

Separation efficiency

The capacity for separating the dirt in the medium circulating in the closed circuits of the hydronic systems depends on three factors:

1. It increases as the size and mass of the dirt particle increases. The larger and heavier dirt particles drop before the lighter ones.
2. It increases as the fluid velocity decreases. When the velocity decreases, there is a low-velocity-zone inside the dirt separator and the dirt particles separate more easily.
3. It increases as the number of recirculations increases. The medium in the circuit, flowing through the dirt separator a number of times during operation, is subjected to a continuous separation, until the dirt particles are completely removed.

The special design of the internal mesh element in the Caleffi DIRTAL® and DIRTMAG® dirt separator, is able to completely separate the dirt particles in the circuit down to a minimum particle size of 5 µm (0.2 mil), including 100% ferrous impurities. The adjacent graph illustrates how these separators quickly remove nearly all the dirt particles. After only 50 recirculations, approximately one day of operation, up to 100% is effectively removed from the circuit for particles of diameter greater than 100 µm (3.9 mil) and on average up to 80% taking account of the smallest particles. The continual passing of the medium during normal operation of the system gradually leads to complete dirt removal.

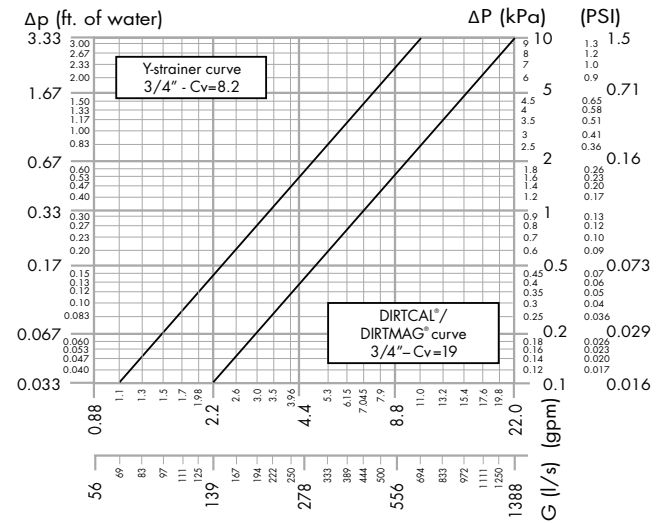

Hydraulic characteristics

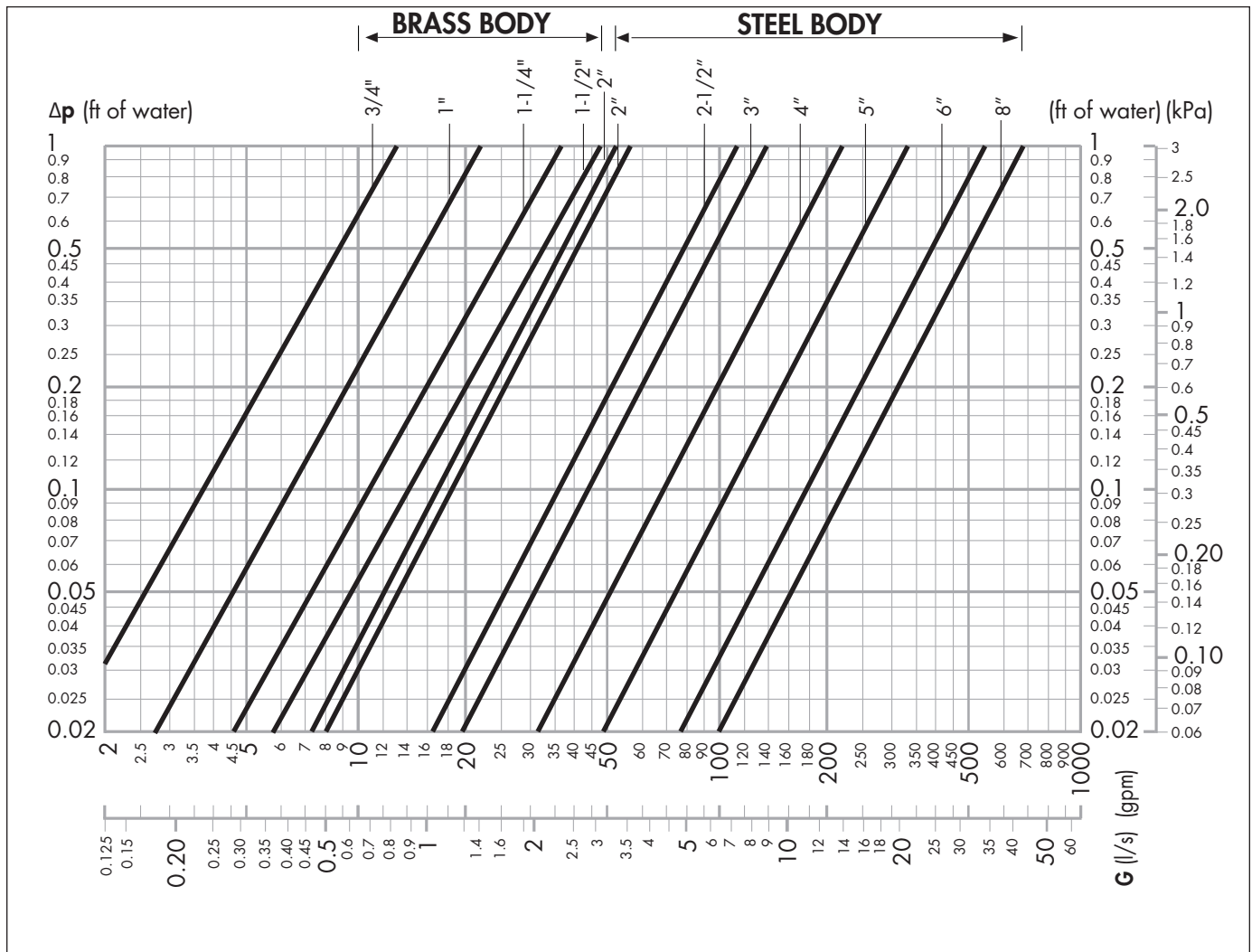

ft of water x .433 = psi

		Brass body					
		Size	3/4"	1"	1 1/4"	1 1/2"	2"
4.0 f/s	GPM		6	9	15	24	36
	l/s		0.4	0.57	1.0	1.5	2.3
	Cv		19	32	56	73	81

		DIRTCAL® steel body						
		Size	2"	2 1/2"	3"	4"	5"	6"
4.0 f/s	GPM		37	63	95	149	259	380
	l/s		2.3	4.0	6.0	9.4	16.3	24.9
10.0 f/s	GPM		89	150	227	355	816	904
	l/s		5.6	9.5	14.3	22.4	51.5	57
	Cv		88	176	211	328	520	842

		DIRTMAG® steel body							
		Size	2"	2 1/2"	3"	4"	5"	6"	8"
4.0 f/s	GPM		37	63	95	149	259	380	643
	l/s		2.3	4.0	6.0	9.4	16.3	24.9	40.6
	Cv		88	176	211	328	520	842	1,053

Insulation shells

The brass DIRTAL® series 5462 and the brass DIRTMAG® series 5463 can be supplied with optional insulated covers, code CBN5462xx series purchased separately, to minimize heat loss.

Code	Size
CBN546205	For ¾" & 1" DIRTAL®, DIRTMAG®
CBN546207	For 1" & 1½" DIRTAL®, DIRTMAG®
CBN546209	For 2" DIRTAL®, DIRTMAG®

Technical specifications

Material: closed cell expanded PE-X
 Thickness: 25/64" (10 mm)
 Density - inner part: 1.9 lb/ft³ (30 kg/m³)
 - outer part: 3.1 lb/ft³ (50 kg/m³)
 Thermal conductivity (DIN 52612):
 - at 32°F (0°C): 0.263 BTU-in/hr-ft²·°F (0.038 W/(m·K))
 - at 104°F (40°C): 0.312 BTU-in/hr-ft²·°F (0.045 W/(m·K))
 Coefficient of resistance to water vapor (DIN 52615): >1,300
 Working temperature range: 32–212°F (0–100°C)
 Reaction to fire (DIN 4102): class B2

Removing insulation and draining impurities (D)

1. Remove the insulation by taking off the bottom casing of the collection chamber first, and if necessary, the top insulation casing later.
2. Remove the magnetic ring containing the two magnets, that during operation attracted the ferrous particles.
3. Flush out the ferrous and nonferrous debris by turning the handle to open the drain valve.
4. When finished, replace the insulation shells.



Installation

The dirt separator must always be installed in a vertical position, preferably on the return circuit upstream of the boiler (or chiller). This enables it to intercept dirt particles already present in the circuit, particularly when it is first started, before they reach the boiler (or chiller). Flow direction for the DIRTAL® and DIRTMAG® dirt separators is bidirectional, flowing in either direction is permitted.

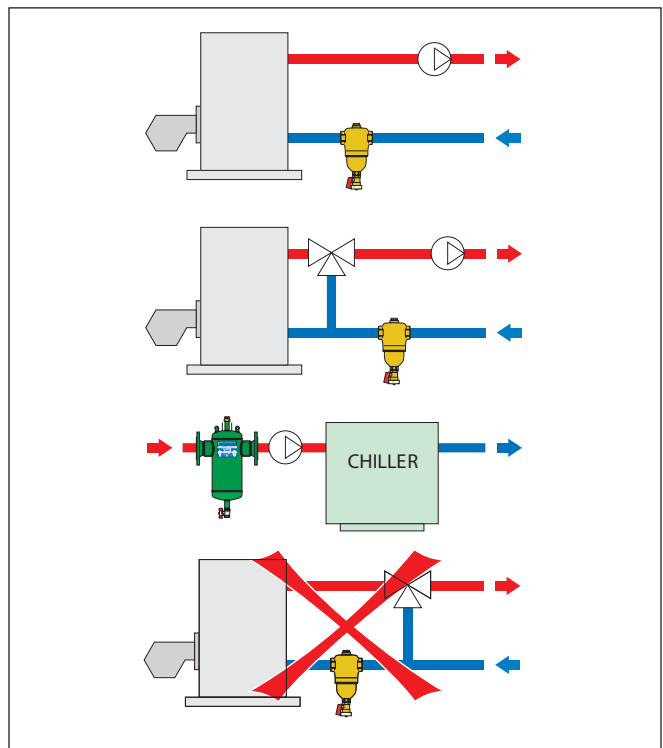
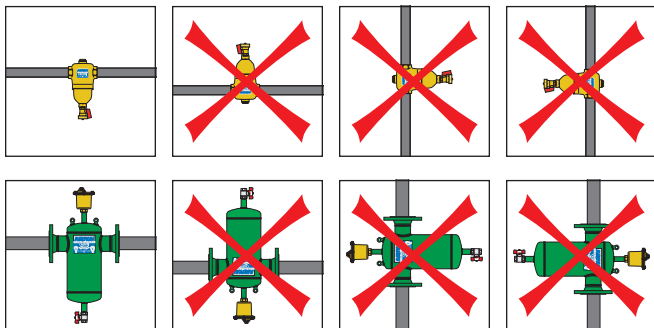

Application diagram

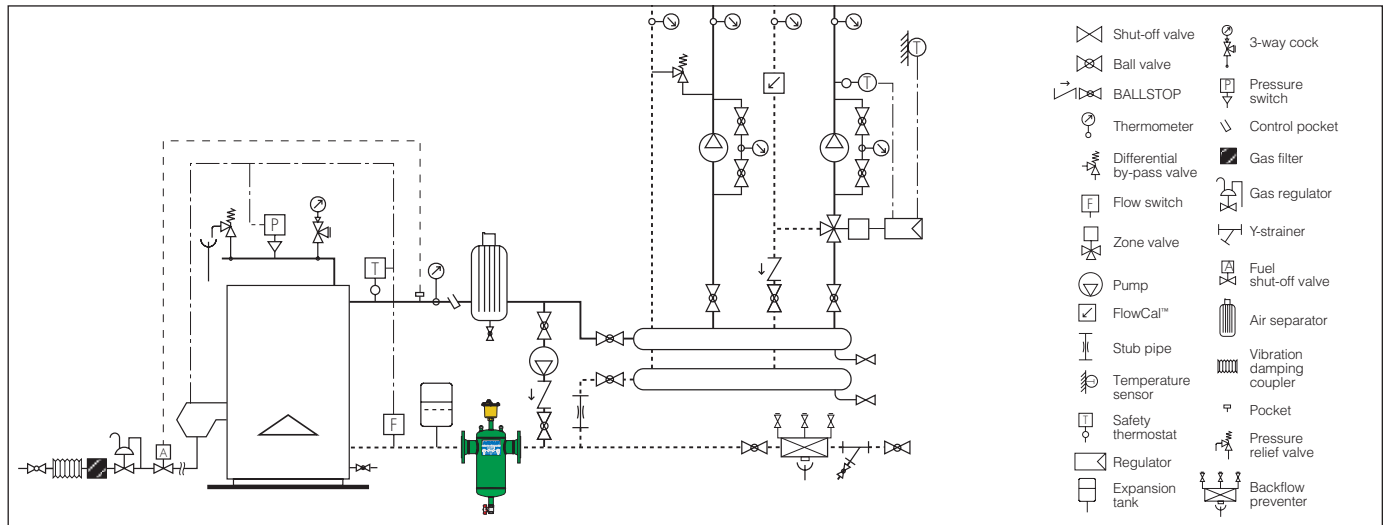

SPECIFICATION SUMMARIES

5462 Series DIRTCAL® — Brass with Sweat and NPT connections

Dirt separator in brass. NPT threaded connections from 3/4" to 2", integral sweat connections 1" to 2", and integral press connections 1" and 1-1/4". Top connection 1/2" FNPT (with plug). Drain valve with 3/4" garden hose connection. Internal mesh element of glass reinforced nylon PA66G30, removable for cleaning. Brass body. EPDM hydraulic seals. Suitable fluids: water or 50% maximum glycol solution. Maximum working pressure 150 psi (10 bar), Temperature range 32 to 250°F (0 to 120°C). Particle separation capacity: to 5 µm (0.2 mil). Pre-formed insulation shells available separately for field installation. Provide with optional automatic air vent, Caleffi code 502243A.

5463 Series DIRTMAG® — Brass with Sweat and NPT connections

Dirt separator with magnet in brass. NPT threaded and integral sweat connections 1" to 2", and integral press connections 1" and 1-1/4". Top connection 1/2" FNPT (with plug). Drain valve with 3/4" garden hose connection. Internal mesh element of glass reinforced nylon PA66G30, removable for cleaning. Brass body with an external removable magnet ring, neodymium rare-earth. EPDM hydraulic seals. Suitable fluids: water or 50% maximum glycol solution. Maximum working pressure 150 psi (10 bar), Temperature range 32 to 250°F (0 to 120°C). Particle separation capacity: to 5 µm (0.2 mil). Ferrous impurities separation efficiency: up to 100% removal. Pre-formed insulation shells available separately for field installation. Provide with optional automatic air vent, Caleffi code 502243A.

5465 Series DIRTCAL® — Flanged Steel

Dirt separator in steel. ANSI B16.5 CLASS 150 RF flanged connections from 2" to 4". Top connection 3/4" NPT male (with cap). Supplied with drain ball valve brass body with 1" NPT for drain. Internal mesh element of stainless steel. Non-asbestos fiber hydraulic seals. Suitable fluids: water or 50% maximum glycol solution. Maximum working pressure 150 psi (10 bar). Temperature range 32 to 270°F (0 to 132°C). Particle separation capacity: to 5 µm (0.2 mil). Provide with optional automatic air vent, Caleffi code 501502A.

5465M Series DIRTMAG® — Flanged Steel

Dirt separator with magnet in steel. ANSI B16.5 CLASS 150 RF flanged connections from 2" to 4". Top connection 3/4" NPT male (with cap). Supplied with drain ball valve brass body with 1" NPT for drain. Internal mesh element of stainless steel and HDPE. Steel body with a stack of neodymium rare-earth magnets inside a brass dry-well, removable for purging. Non-asbestos fiber hydraulic seals. Suitable fluids: water or 50% maximum glycol solution. Maximum working pressure 150 psi (10 bar). Temperature range 32 to 270°F (0 to 132°C). Particle separation capacity: to 5 µm (0.2 mil). Ferrous impurities separation efficiency: up to 100% removal. Provide with optional automatic air vent, Caleffi code 501502A.

NA5465 Series DIRTCAL® — Flanged Steel ASME, CRN

Dirt separator in steel. ANSI B16.5 CLASS 150 RF flanged connections from 2" to 6". Top connection 3/4" NPT male (with cap). Supplied with drain ball valve brass body with 1" NPT for drain. Internal mesh element of stainless steel. Non-asbestos fiber hydraulic seals. Suitable fluids: water or 50% maximum glycol solution. Maximum working pressure 150 psi (10 bar). Temperature range 32 to 270°F (0 to 132°C). Particle separation capacity: to 5 µm (0.2 mil). The separator is designed and built in accordance with Section VIII, Division 1 of the ASME Boiler and Pressure Vessel Code and tagged and registered with the National Board of Boiler and Pressure Vessel Inspectors, CRN Registered, and stamped for 150 psi (10 bar) working pressure, with ASME U stamp. Provide with optional automatic air vent, Caleffi code 501502A.

5465M Series DIRTMAG® — Flanged Steel ASME

Dirt Separator with magnet in steel. ANSI B16.5 CLASS 150 RF flanged connections from 2" to 8". Top connection 3/4" NPT male (with cap). Supplied with drain ball valve brass body with 1" NPT female (code NA39753, separator size 2" to 6") or 2" NPT female (code NA59600, separator size 8") for drain. For separator size 8" only thermometer pocket well on inlet/outlet flanges 1/2" NPT female. Internal mesh element of stainless steel and HDPE. Steel body with a stack of neodymium rare-earth magnets inside a brass dry-well, removable for purging. Non-asbestos fiber hydraulic seals. Suitable fluids: water or 50% maximum glycol solution. Maximum working pressure 150 psi (10 bar). Temperature range 32°F to 270°F (0°C to 132°C). Particle separation capacity: to 5 µm (0.2 mil). Ferrous impurities separation efficiency: up to 100% removal. The separator is designed and built in accordance with Section VIII, Division 1 of the ASME Boiler and Pressure Vessel Code and tagged and registered with the National Board of Boiler and Pressure Vessel Inspectors and stamped for 150 psi (10 bar) working pressure, with ASME U-stamp. CRN pending, contact Caleffi. Provide with automatic air vent, Caleffi code 501502A.

We reserve the right to change our products and their relevant technical data, contained in this publication, at any time and without prior notice.



Caleffi North America, Inc.
3883 W. Milwaukee Road
Milwaukee, WI 53208
Tel: 414-238-2360 · Fax: 414-238-2366
sales@caleffi.com · www.caleffi.com
© Copyright 2016 Caleffi North America, Inc.